

## 1. Introduction

Modules **A-130 (Linear VCA)** and **A-131 (Exp. VCA)** provide **voltage-controlled amplification**.

 This section of the manual applies equally to the **A-130** and **A-131**, because apart from the one difference of their response curves, they are otherwise identical.

For audio signals, you would normally use the exponential VCA (A-131), and for control voltages, the linear VCA (A-130). It doesn't always have to be that way, though.

The amount of amplification the VCAs provide is determined by the voltage at the CV input, and the position of the gain control, which sets the overall gain in the system.

The VCA has **two audio inputs**, each with an attenuator. They are amplified by an amount determined by the combination of the gain and the two CV controls.

## 2. VCA - overview

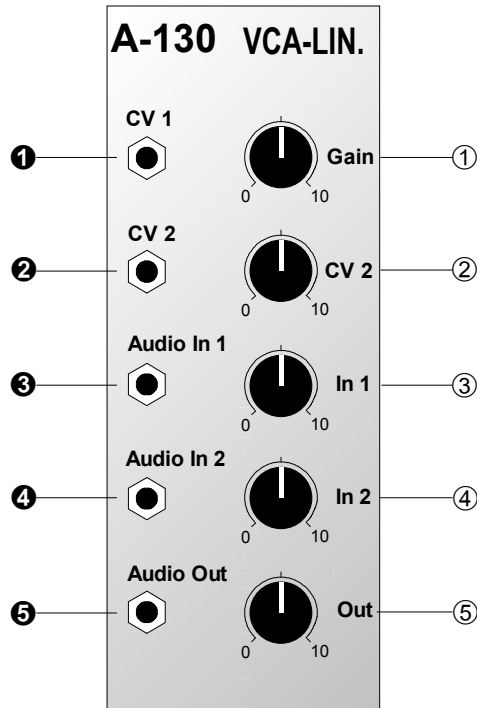

### Controls:

- ① **Gain:** Overall gain control
- ② **CV 2:** CV attenuator for input ②
- ③ **IN 1:** Attenuator for audio input ③
- ④ **IN 2:** Attenuator for audio input ④
- ⑤ **Out:** Attenuator for the output signal

### In / Outputs:

- ① **CV 1:** Control voltage input
- ② **CV 2:** ditto, with attenuator
- ③ **Audio In 1:** Audio input
- ④ **Audio In 2:** ditto
- ⑤ **Audio Out:** Audio output for the combined audio signals input at ③ and ④ and then amplified by the VCA.

### 3. Controls

The **A-130** has a **linear** response: the amplification is in direct linear proportion to the control voltage input (see Fig. 1).

The **A-131** has an **exponential** (or **logarithmic**) response. That means that control voltage changes have less effect at low levels of amplification than at high levels, and makes the A-131 more sensitive and suitable for subtle changes at low levels (see Fig. 1).

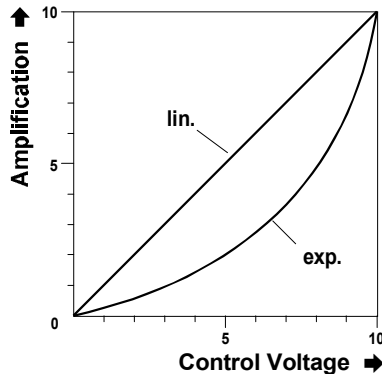

**Fig. 1:** Response curves for the A-130 and A-131

#### ① Gain

This controls the overall gain of the VCA. At "0", with no control voltage present, there is no amplification at all: no signal is present at the VCA's output. Once the gain control is turned up, amplification occurs, even if there is no CV input present. The gain control shifts the whole VCA response upwards (see Fig. 2).

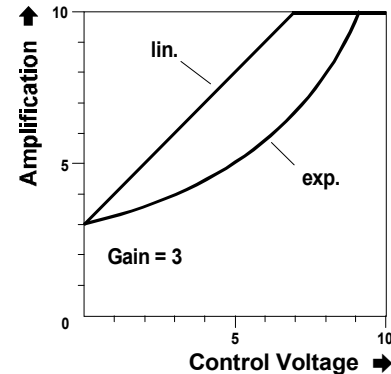

**Fig. 2:** Effect of gain control on VCA response



Note that if a control voltage is partially negative (for instance an LFO modulating the VCA) you need to set the VCA gain above zero, since otherwise the input signal is only amplified when the modulation CV is positive (see Fig. 3).

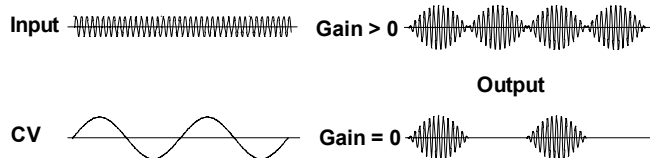



Fig. 3: VCA output level at different gain settings.

## ② CV 2

This attenuator affects the level of voltage control at socket ②. It controls the amount of effect the CV has on amplification.

## ③ IN 1 • ④ IN 2

Attenuators ③ and ④ control the level of the **signals input** into the VCA.

 If the output signal **distorts** in an unwanted way, turn down the input level, using control ③ and/or ④.

## ⑤ Out

This attenuator controls the total volume of the VCA's output.

## 4. In / Outputs

### ① CV 1 • ② CV 2

Sockets ① and ② are control voltage inputs, whose voltages are combined. The effective range of the VCA goes from 0 V (no amplification) to +5 V (maximum amplification).

### ③ Audio In 1 • ④ Audio In 2

The signals you wish to amplify are input through audio inputs ③ and/or ④.

### ⑤ Audio Out

The output signal here is the audio inputs amplified by the VCA..

## 5. User examples

### Typical voltage controlled amplification

A standard VCA patch is shown in Fig. 4. An ADSR envelope produces a time-dependent amplification curve, which can affect any sound source you choose. The curve can be very quick (with a fast envelope) or it can produce long, slow changes in the volume of a sound.

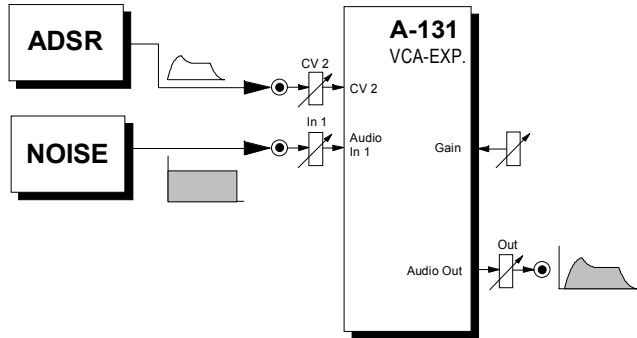

Fig. 4: Time dependent amplification using an ADSR

### Amplitude modulation

In Fig. 5, an LFO is modulating an A-130 linear VCA (with Gain > 0), so that the amplification changes cyclically with the LFO's voltage (**Amplitude modulation/AM**.)

With an LFO frequency in the sub-audio range (1 Hz to around 15 Hz) the result is **Tremolo** (Fig. 5). With a modulation frequency in the audio range, sidebands occur like those produced by FM (Frequency Modulation), and interesting timbres emerge.

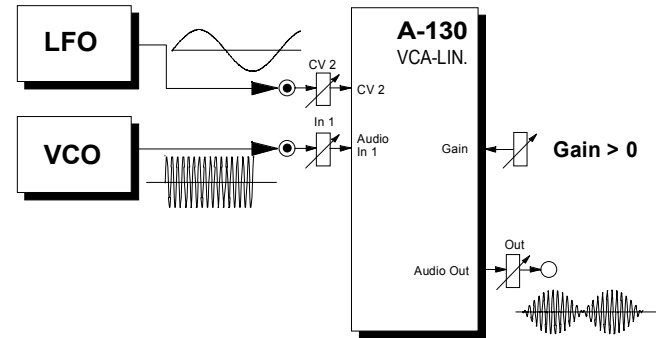

Fig. 5: VCA amplitude modulation with an LFO

Modulation depth is adjusted with control ②.

Fig. 6 shows a way of voltage-controlling this modulation depth using another VCA. In this example, the VCAs have the following functions:

- VCA 1 (A-130): AM control
- VCA 2 (A-131): total volume control
- VCA 3 (A-130): modulation depth control

The voltage control input A to the modulation depth VCA can come from an ADSR, MIDI controller, etc..

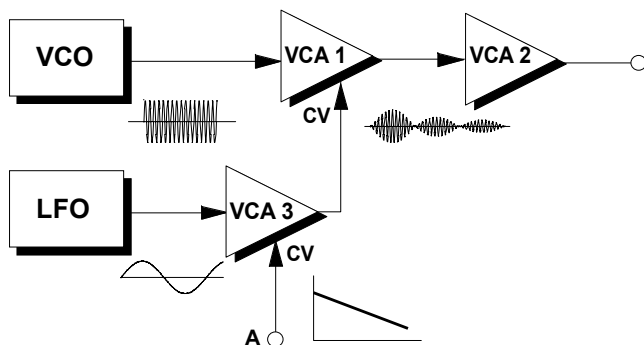

Fig. 6: AM with voltage-controlled modulation depth

### Keyboard control of VCA (tracking)

You can use the CV output from a keyboard to modulate the VCA, and so have **level of amplification determined by the pitch** of a note - what's usually called keyboard tracking.

In the example in Fig. 7, high frequency notes are amplified more than low frequency notes. Use control ① on **VCA 2** to vary the degree of keyboard tracking.

To produce the opposite effect (that is, inverse keyboard tracking, where lower sounds are more amplified than higher ones) patch a **Voltage-Inverter A-175** in before VCA 2 (see Fig. 8).

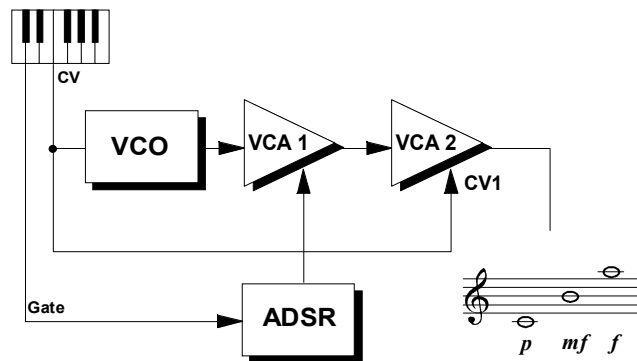

Fig. 7: Keyboard tracking - the higher the pitch, the louder the output

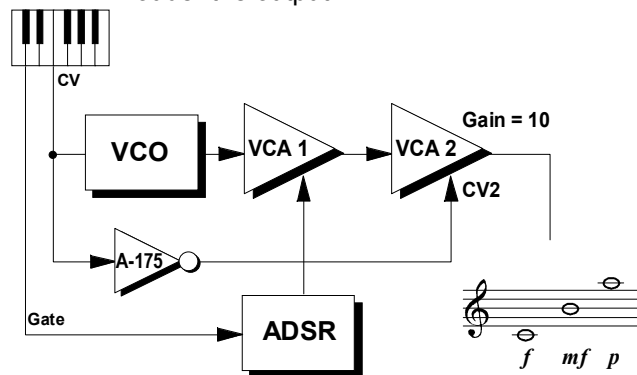

Fig. 8: Inverted keyboard tracking: the higher the pitch, the less amplification.

Set the gain control ① at maximum, and use CV2 control ② to determine the intensity of the effect

## 6. Patch-Sheet

The following diagrams of the module can help you recall your own **Patches**. They're designed so that a complete 19" rack of modules will fit onto an A4 sheet of paper.

Photocopy this page, and cut out the pictures of this and your other modules. You can then stick them onto another piece of paper, and create a diagram of your own system.

Make multiple copies of your composite diagram, and use them for remembering good patches and set-ups.



- Draw in patchleads with colored pens.
- Draw or write control settings in the little white circles.

